

30V WLED Driver with Integrated Power Diode

Check for Samples: [TPS61158](#)

FEATURES

- 2.7V to 5.5V Input Voltage Range
- 28V Open LED Protection (up to 8 LEDs)
- Integrated 0.6A 30V Internal Switch FET and Power Diode
- 750kHz Switching Frequency
- Flexible Digital and PWM Brightness Control
 - 1-Wire Control Interface (EasyScale)
 - PWM Dimming Control Interface
- Up to 100:1 PWM Dimming Ratio
- Integrated Loop Compensation
- Built-in Soft Start
- Built-in WLED Open protection
- Thermal Shutdown
- 2mm x 2mm x 0.8mm 6-pin QFN Package with Thermal Pad

APPLICATIONS

- Feature Phones
- Smart Phones
- Portable Media Players
- Ultra Mobile Devices
- GPS Receivers
- Backlight for Small and Media Form Factor LCD Display

DESCRIPTION

With 30V rated integrated switch FET and power diode, the TPS61158 is a boost converter that drives LEDs in series. The boost converter runs at 750kHz fixed switching frequency to reduce output ripple, improve conversion efficiency, and allows for the use of small external components.

The default white LED current is set with the external sensor resistor RFB, and the feedback voltage is regulated to 200mV, as shown in the typical application. During the operation, the LED current can be controlled using the 1-wire digital interface (Easyscale™ protocol) through the CTRL pin. Alternatively, a pulse width modulation (PWM) signal can be applied to the CTRL pin through which the duty cycle determines the feedback reference voltage. In either digital or PWM mode, the TPS61158 does not burst the LED current; therefore, it does not generate audible noises on the output capacitor. For maximum protection, the device features integrated open LED protection that disables the TPS61158 to prevent the output voltage from exceeding the IC's absolute maximum voltage ratings during open LED conditions. The TPS61158 is available in a space-saving, 2mm x 2mm QFN package with thermal pad.

TYPICAL APPLICATION

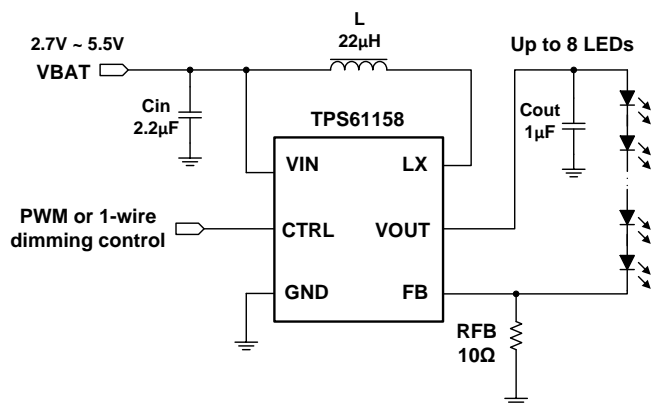

Please be aware that an important notice concerning availability, standard warranty, and use in critical applications of Texas Instruments semiconductor products and disclaimers thereto appears at the end of this data sheet.

TPS61158

SLVSR3 –MAY 2013

www.ti.com



These devices have limited built-in ESD protection. The leads should be shorted together or the device placed in conductive foam during storage or handling to prevent electrostatic damage to the MOS gates.

ORDERING INFORMATION⁽¹⁾

ORDERING	PACKAGE	PACKAGE MARKING
TPS61158DRV	QFN 2 x 2 6L - DRV	SIW

- (1) For the most current package and ordering information, see the Package Option Addendum at the end of this document, or see the TI website at www.ti.com.

ABSOLUTE MAXIMUM RATINGS

over operating free-air temperature range (unless otherwise noted)⁽¹⁾

		VALUE		UNIT
		MIN	MAX	
Voltage range ⁽²⁾	VIN	-0.3	6	V
	VOUT, LX	-0.3	30	V
	FB, CTRL	-0.3	7	V
ESD rating	HBM		2	kV
	CDM		500	V
Continuous power dissipation		See Thermal Information Table		
Operating junction temperature range		-40	150	°C
Storage temperature range		-65	150	°C

- (1) Stresses beyond those listed under absolute maximum ratings may cause permanent damage to the device. These are stress ratings only, and functional operation of the device at these or any other conditions beyond those indicated under recommended operating conditions is not implied. Exposure to absolute-maximum-rated conditions for extended periods may affect device reliability.
- (2) All voltage values are with respect to network ground terminal.

THERMAL INFORMATION

THERMAL METRIC ⁽¹⁾		TPS61158	UNITS
		DRV (6 PINS)	
θ_{JA}	Junction-to-ambient thermal resistance ⁽²⁾	70.4	°C/W
θ_{JCTop}	Junction-to-case (top) thermal resistance ⁽³⁾	94.8	
θ_{JB}	Junction-to-board thermal resistance ⁽⁴⁾	39.8	
ψ_{JT}	Junction-to-top characterization parameter ⁽⁵⁾	2.5	
ψ_{JB}	Junction-to-board characterization parameter ⁽⁶⁾	40.2	
θ_{JCbott}	Junction-to-case (bottom) thermal resistance ⁽⁷⁾	10.2	

- (1) For more information about traditional and new thermal metrics, see the *IC Package Thermal Metrics* application report, [SPRA953](http://www.ti.com/lit/zip/SRA953).
- (2) The junction-to-ambient thermal resistance under natural convection is obtained in a simulation on a JEDEC-standard, high-K board, as specified in JESD51-7, in an environment described in JESD51-2a.
- (3) The junction-to-case (top) thermal resistance is obtained by simulating a cold plate test on the package top. No specific JEDEC-standard test exists, but a close description can be found in the ANSI SEMI standard G30-88.
- (4) The junction-to-board thermal resistance is obtained by simulating in an environment with a ring cold plate fixture to control the PCB temperature, as described in JESD51-8.
- (5) The junction-to-top characterization parameter, ψ_{JT} , estimates the junction temperature of a device in a real system and is extracted from the simulation data for obtaining θ_{JA} , using a procedure described in JESD51-2a (sections 6 and 7).
- (6) The junction-to-board characterization parameter, ψ_{JB} , estimates the junction temperature of a device in a real system and is extracted from the simulation data for obtaining θ_{JA} , using a procedure described in JESD51-2a (sections 6 and 7).
- (7) The junction-to-case (bottom) thermal resistance is obtained by simulating a cold plate test on the exposed (power) pad. No specific JEDEC standard test exists, but a close description can be found in the ANSI SEMI standard G30-88.

RECOMMENDED OPERATING CONDITIONS

over operating free-air temperature range (unless otherwise noted)

		MIN	NOM	MAX	UNIT
V _{IN}	Input voltage range	2.7		5.5	V
V _{OUT}	Output voltage range	V _{in}		29	V
I _{OUT}	Output load current			30	mA
L	Inductor	10		22	μH
C _I	Input capacitor	1.0		10	μF
C _O	Output capacitor	0.47		2.2	μF
F _{PWM}	Input PWM signal frequency range	20		100	kHz
T _A	Operating ambient temperature	-40		85	°C
T _J	Operating junction temperature	-40		125	°C

ELECTRICAL CHARACTERISTICS

 V_{IN}=3.6V, CTRL=High, IFB current=20mA, IFB voltage=200mV, T_A = -40°C to 85°C, typical values are at T_A = 25°C (unless otherwise noted)

PARAMETER	TEST CONDITIONS	MIN	TYP	MAX	UNIT	
POWER SUPPLY						
V _{IN}	Input voltage range	2.7		5.5	V	
V _{IN_UVLO}	V _{IN} under voltage lockout threshold	V _{IN} ramp down	2.2	2.35	V	
		V _{IN} ramp up	2.5	2.65		
V _{IN_HYS}	V _{IN} under voltage lockout hysteresis		275		mV	
I _Q	Operating quiescent current into VIN	Device enable, no switching and no load (V _{FB} = 0.4V)	0.3	0.5	mA	
		Device enable, switching 750kHz and no load (V _{FB} = 0V)	0.5	1.65		
I _{SD}	Shutdown current	CTRL = GND	0.1	1	μA	
CONTROL LOGIC AND TIMING						
V _H	CTRL logic high voltage	1.2			V	
V _L	CTRL logic Low voltage			0.4	V	
R _{PD}	CTRL pin internal pull-down resistor	V _{CTRL} = 1.8 V	300		kΩ	
t _{SD}	CTRL pulse width to shutdown	CTRL from high to low	3.5		ms	
VOLTAGE AND CURRENT REGULATION						
V _{REF}	Voltage feedback regulation voltage	Duty = 100%	194	200	206	mV
I _{FB}	FB pin bias current	V _{FB} = 200mV		2		μA
t _{REF}	V _{REF} filter time constant		230			μs
POWER SWITCH AND DIODE						
R _{DS(ON)}	N-channel MOSFET on-resistance	V _{IN} = 3.6 V, T _A = 25°C, I _{OUT} = 100 mA	0.6	1		Ω
V _F	Power diode forward voltage	I _{DIODE} = 0.2A	0.75	1		V
I _{LEAK_LX}	LX pin leakage current	V _{LX} = 28V	0.1	2		μA
OSCILLATOR						
f _{SW}	Oscillator frequency		600	750	900	kHz
D _{max}	Maximum duty cycle of boost switching	V _{FB} = 0V, measured on the drive signal of the switch MOSFET	88%	94%		
PROTECTION AND SOFTSTART						
I _{LIM}	NMOS current limit	V _{IN} = 3.6V, D = D _{MAX} , T _A = 0°C to 85°C,	0.5	0.6	0.7	A
I _{LIM_Start}	Start up current limit		360			mA
t _{LIM_Start}	Time step for start up current limit		8			ms
V _{OVP}	Open LED protection threshold	Tested at V _{OUT} pin	27.5	28.2	29	V

ELECTRICAL CHARACTERISTICS (continued)

$V_{IN}=3.6V$, CTRL=High, IFB current=20mA, IFB voltage=200mV, $T_A = -40^{\circ}C$ to $85^{\circ}C$, typical values are at $T_A = 25^{\circ}C$ (unless otherwise noted)

PARAMETER		TEST CONDITIONS	MIN	TYP	MAX	UNIT
EasyScale TIMING						
t_{es_detect}	Easy Scale detection time ⁽¹⁾	CTRL low	450			μs
t_{es_delay}	Easy Scale detection delay		100			μs
t_{es_win}	Easy Scale detection window time	Measured from CTRL high	3.5			ms
t_{start}	Start time of program stream		3.5			μs
t_{EOS}	End time of program stream		3.5		600	μs
t_{H_LB}	High time of low bit	Logic 0	3.5		300	μs
t_{L_LB}	Low time of low bit	Logic 0	2 x t_{H_LB}		600	μs
t_{H_HB}	High time of high bit	Logic 1	2 x t_{L_HB}		600	μs
t_{L_HB}	Low time of high bit	Logic 1	3.5		300	μs
V_{ACKNL}	Acknowledge output voltage low	Open drain, $R_{pullup} = 15k\Omega$ to V_{IN}			0.4	V
t_{valACK}	Acknowledge valid time	See ⁽²⁾			3.5	μs
t_{ACKN}	Duration of acknowledge condition	See ⁽²⁾			900	μs
THERMAL SHUTDOWN						
$T_{shutdown}$	Thermal shutdown threshold			160		$^{\circ}C$
T_{hys}	Thermal shutdown hysteresis			15		$^{\circ}C$

- (1) To select EasyScale mode, the CTRL pin has to be low for more than t_{es_detect} during t_{es_win}
- (2) Acknowledge condition active 0, this condition will only be applied in case the RFA bit is set. Open drain output, line needs to be pulled high by the host with resistor load.

DEVICE INFORMATION

(TOP VIEW)

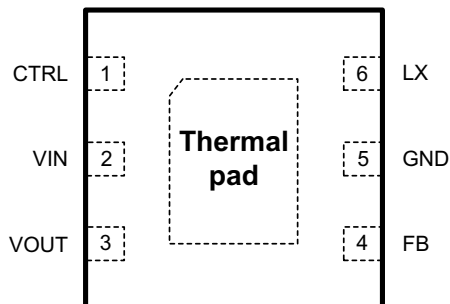
PIN FUNCTIONS

PIN		I/O	DESCRIPTION
NO.	NAME		
1	CTRL	I	Control pin of the boost converter. It is a multi-functional pin which can be used for enable control, PWM and digital dimming.
2	VIN	I	The input supply pin for the IC. Connect VIN to a supply voltage between 2.7V and 5.5V.
3	VOUT	O	Output of the boost converter.
4	FB	I	Feedback pin for current. Connect the sense resistor from FB to GND.
5	GND	O	Ground
6	LX	I	This is the switching node of the IC. Connect the inductor between the VIN and LX pin.
7	Thermal Pad		The thermal pad should be soldered to the analog ground plane. If possible, use thermal via to connect to ground plane for ideal power dissipation.

TYPICAL CHARACTERISTICS

TABLE OF GRAPHS

TITLE	DESCRIPTION	FIGURE
Dimming Efficiency	$V_{IN} = 3.6V$; 6 LEDs ($V_{OUT} = 18.3V$), 8 LEDs ($V_{OUT} = 24.4V$); $R_{FB} = 10\Omega$; PWM Freq = 40kHz; $L = 22\mu H$	Figure 1
Dimming Efficiency	$V_{IN} = 3V, 3.6V, 4.2V, 5V$; 6 LEDs ($V_{OUT} = 18.3V$); $R_{FB} = 10\Omega$; PWM Freq = 40kHz; $L = 22\mu H$	Figure 2
Dimming Efficiency	$V_{IN} = 3V, 3.6V, 4.2V, 5V$; 8 LEDs ($V_{OUT} = 24.4V$); $R_{FB} = 10\Omega$; PWM Freq = 40kHz; $L = 22\mu H$	Figure 3
Switch Current Limit vs Temperature	$V_{IN} = 3.6V$	Figure 4
Switch Current Limit vs V_{IN}	$T_A = 25^\circ C$	Figure 5
FB Voltage vs EasyScale Step	$V_{IN} = 3.6V$	Figure 6
FB voltage vs PWM duty cycle	$V_{IN} = 3.6V$; PWM Freq = 20kHz and 40kHz	Figure 7
Output Ripple at PWM Dimming	$V_{IN} = 3.6V$; 8 LEDs ($V_{OUT} = 24.4V$); $R_{FB} = 10\Omega$; PWM Freq = 20kHz; $L = 22\mu H$	Figure 8
Switching Waveform	$V_{IN} = 3.6V$; 8 LEDs ($V_{OUT} = 24.4V$); $R_{FB} = 10\Omega$; PWM Duty = 100%; $L = 22\mu H$	Figure 9
Switching Waveform	$V_{IN} = 3.6V$; 8 LEDs ($V_{OUT} = 24.4V$); $R_{FB} = 10\Omega$; PWM Freq = 20kHz; PWM Duty = 25%; $L = 22\mu H$	Figure 10
Startup Waveform	$V_{IN} = 3.6V$; 8 LEDs ($V_{OUT} = 24.4V$); $R_{FB} = 10\Omega$; PWM Duty = 100%; $L = 22\mu H$	Figure 11
Startup Waveform	$V_{IN} = 3.6V$; 8 LEDs ($V_{OUT} = 24.4V$); $R_{FB} = 10\Omega$; PWM Freq = 20kHz; PWM Duty = 25%; $L = 22\mu H$	Figure 12
Shutdown Waveform	$V_{IN} = 3.6V$; 8 LEDs ($V_{OUT} = 24.4V$); $R_{FB} = 10\Omega$; PWM Duty = 100%; $L = 22\mu H$	Figure 13
Shutdown Waveform	$V_{IN} = 3.6V$; 8 LEDs ($V_{OUT} = 24.4V$); $R_{FB} = 10\Omega$; PWM Freq = 20kHz; PWM Duty = 25%; $L = 22\mu H$	Figure 14
Open LED Protection	$V_{IN} = 3.6V$; 6 LEDs ($V_{OUT} = 18.3V$); $R_{FB} = 10\Omega$; PWM Duty = 100%; $L = 22\mu H$	Figure 15

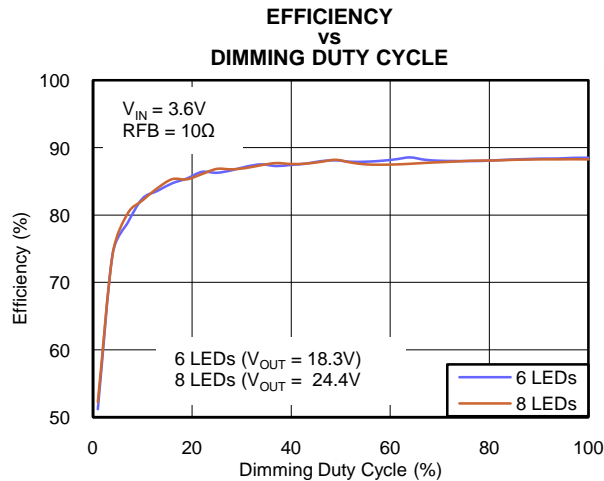

Figure 1.

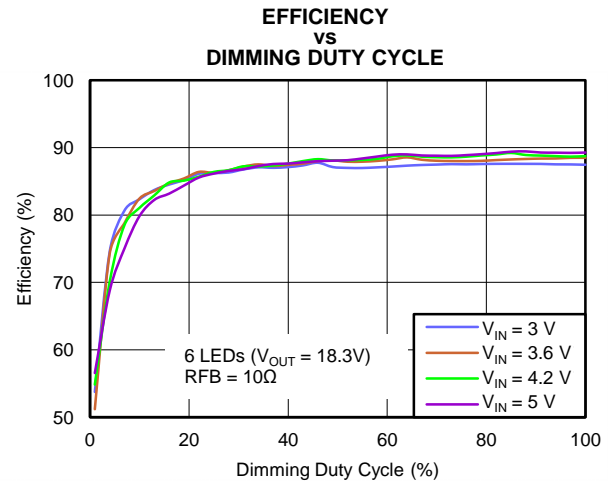

Figure 2.

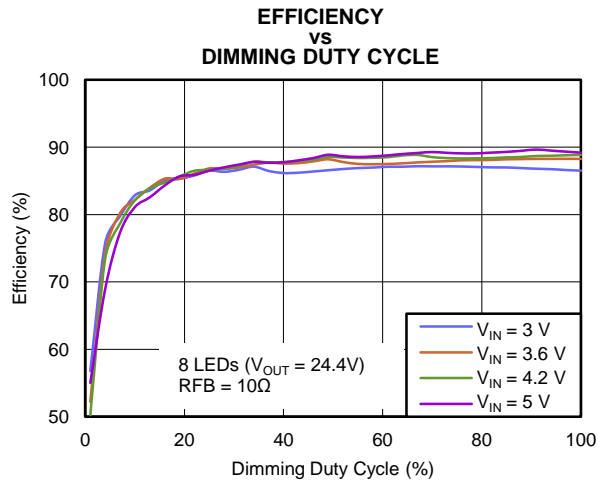

Figure 3.

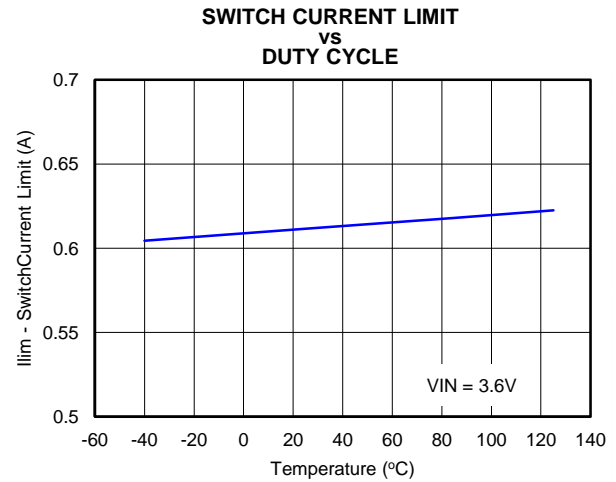

Figure 4.

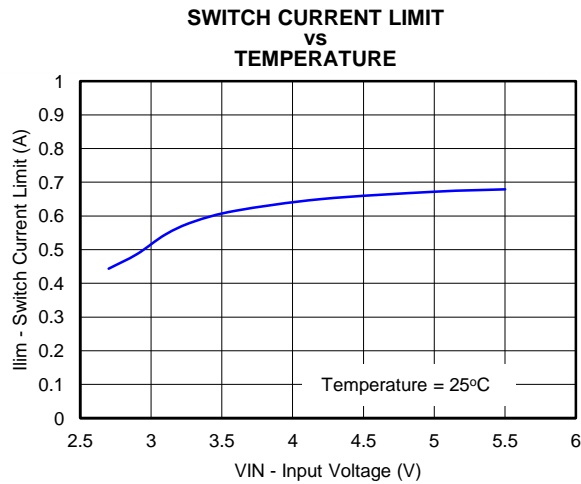

Figure 5.

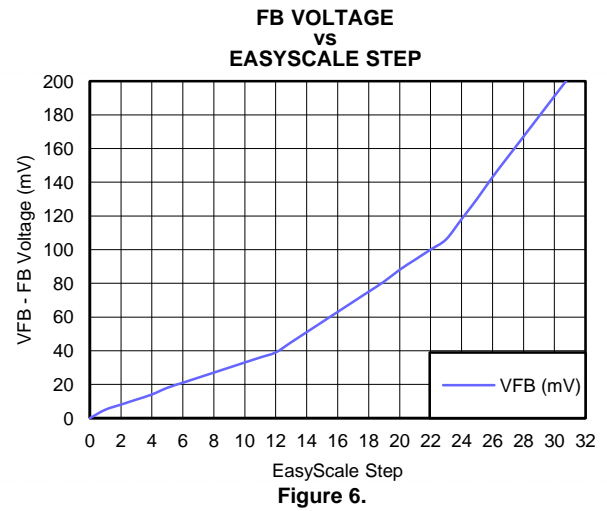

Figure 6.

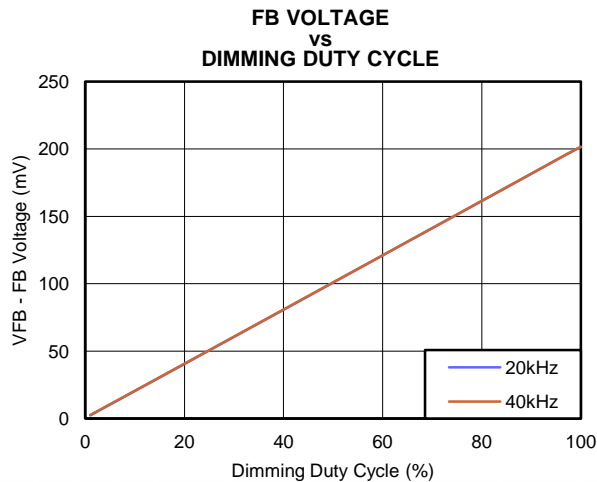

Figure 7.

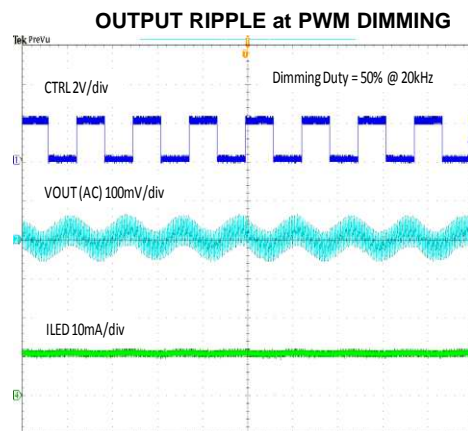

Figure 8.

SWITCHING WAVEFORM - DIMMING DUTY = 100%

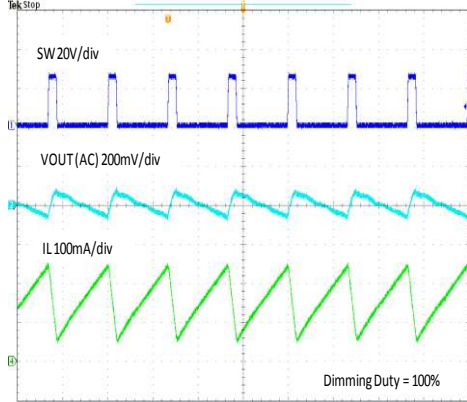

Figure 9.

SWITCHING WAVEFORM - DIMMING DUTY = 25%

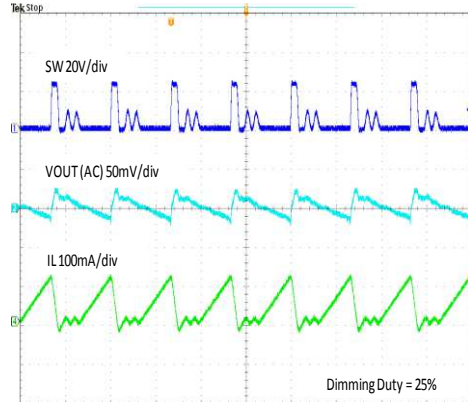

Figure 10.

START-UP DIMMING DUTY = 100%

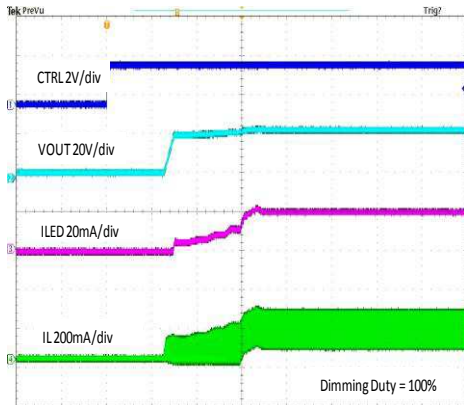

Figure 11.

START-UP DIMMING DUTY = 25%

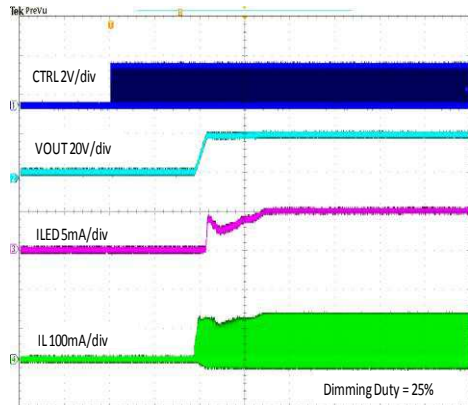

Figure 12.

SHUTDOWN DIMMING DUTY = 100%

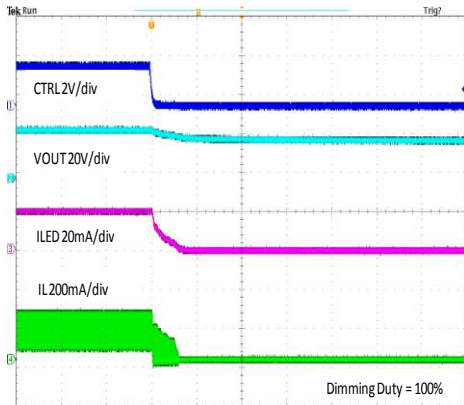

Figure 13.

SHUTDOWN DIMMING DUTY = 25%

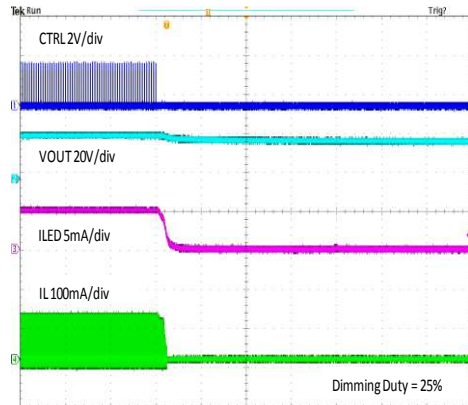

Figure 14.

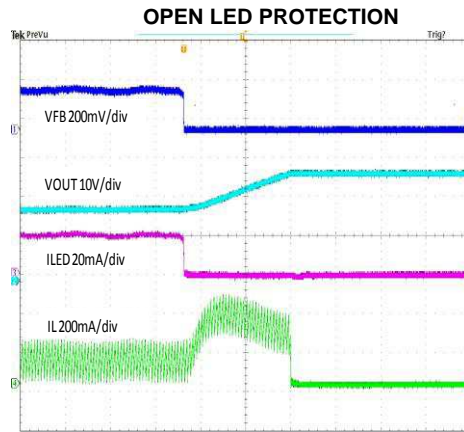

Figure 15.

DETAILED DESCRIPTION

OPERATION

The TPS61158 is a high efficiency boost converter with integrated power diode in a small package size. The device is ideal for driving white LED in series. The serial LED connection provides even illumination by sourcing the same output current through all LEDs, eliminating the need for expensive factory calibration. The device integrates a 30V/0.6A low side switch MOSFET and a 30V power diode, and operates in pulse width modulation (PWM) with 750 kHz fixed switching frequency. For operation see the block diagram. The duty cycle of the converter is set by the error amplifier output and the current signal applied to the PWM control comparator. The control architecture is based on traditional current-mode control; therefore, slope compensation is added to the current signal to allow stable operation for duty cycles larger than 50%. The feedback loop regulates the FB pin to a low reference voltage (200mV typical), reducing the power dissipation in the current sense resistor.

SOFT START-UP

Soft-start circuitry is integrated into the IC to avoid a high inrush current during start-up. After the device is enabled, the voltage at FB pin ramps up to the reference voltage in 32 steps with each step taking 341µs. This ensures that the output voltage rises slowly to reduce the input current. Additionally, during the start up process, the current limit of the switch is set to half of the normal current limit spec. During this period, the input current is kept below 360mA (typical). See the start-up waveform of a typical example.

SHUTDOWN

The TPS61158 enters shutdown mode when the CTRL voltage is logic low for more than 3.5ms. During shutdown, the input supply current for the device is less than 1µA (max). Although the internal FET does not switch in shutdown mode, there is still a DC current path between the input and the LEDs through the inductor and the power diode. The minimum forward voltage of the LED array must exceed the maximum input voltage to ensure that the LEDs remain off in shutdown. In the typical application with two or more LEDs, the forward voltage is large enough to reverse bias the diode and keep leakage current low.

CURRENT PROGRAM

The FB voltage is regulated by a low 0.2V reference voltage. The LED current is programmed externally using a current-sense resistor RFB in series with the LED string. The value of the RFB is calculated using [Equation 1](#):

$$R_{FB} = \frac{V_{FB}}{I_{LED}} \quad (1)$$

Where:

- R_{FB} = current sense resistor at FB pin
- V_{FB} = 200mV (regulated voltage of FB pin)
- I_{LED} = full-scale output current of LEDs

The output current tolerance depends on the FB voltage accuracy and the current sensor resistor accuracy.

LED BRIGHTNESS DIMMING MODE SELECTION

The CTRL pin is used for the control input for both dimming modes, PWM dimming and 1 wire dimming. The dimming mode for the TPS61158 is selected each time the device is enabled. The default dimming mode is PWM dimming. To enter the 1 wire mode, the following digital pattern on the CTRL pin must be recognized by the IC every time the IC starts from the shutdown mode.

1. Pull CTRL pin high to enable the TPS61158, and to start the 1 wire detection window.
2. After the EasyScale detection delay (t_{es_delay}, 100µs) expires, drive CTRL low for more than the EasyScale detection time (t_{es_detect}, 450µs).
3. The CTRL pin has to be low for more than EasyScale detection time before the EasyScale detection window (t_{es_win}, 3.5ms) expires. EasyScale detection window starts from the first CTRL pin low to high transition.

The IC immediately enters the 1 wire mode once the above 3 conditions are met. The EasyScale communication can start before the detection window expires. Once the dimming mode is programmed, it can not be changed without another start up. This means the IC needs to be shutdown by pulling the CTRL low for 3.5ms and restarts. See the Dimming Mode Detection and Soft Start ([Figure 16](#)) for a graphical explanation.

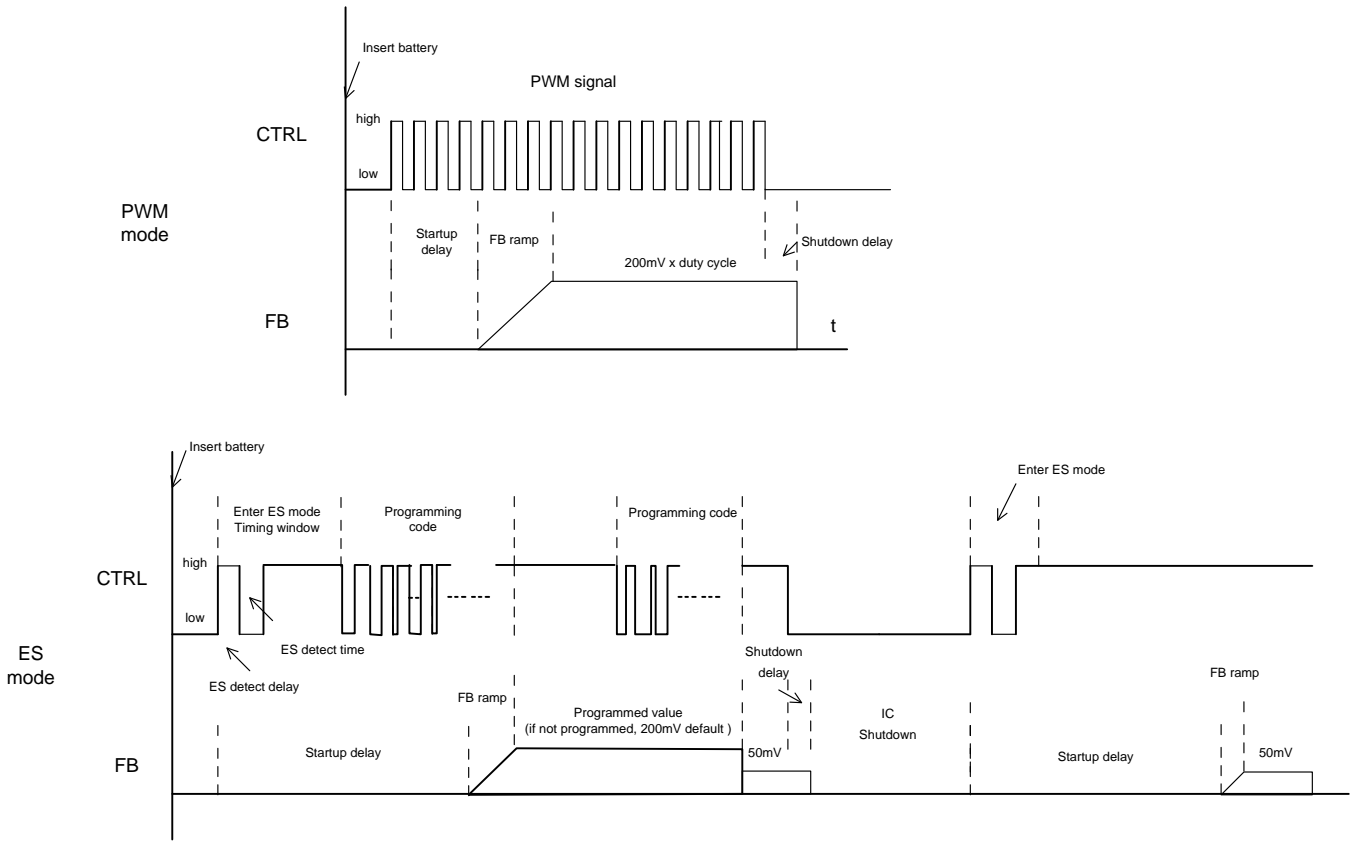

Figure 16. Dimming Mode Detection and Soft Start

PWM BRIGHTNESS DIMMING

When the CTRL pin is constantly high, the FB voltage is regulated to 200mV typically. However, the CTRL pin allows a PWM signal to reduce this regulation voltage; therefore, it achieves LED brightness dimming. The relationship between the duty cycle and FB voltage is given by [Equation 2](#).

$$V_{FB} = \text{Duty} \times 200 \text{ mV} \quad (2)$$

Where:

Duty = duty cycle of the PWM signal
 200 mV = internal reference voltage

As shown in [Figure 17](#), the IC chops up the internal 200mV reference voltage at the duty cycle of the PWM signal. The pulse signal is then filtered by an internal low pass filter. The output of the filter is connected to the error amplifier as the reference voltage for the FB pin regulation. Therefore, although a PWM signal is used for brightness dimming, only the WLED DC current is modulated, which is often referred as analog dimming. This eliminates the audible noise which often occurs when the LED current is pulsed in replica of the frequency and duty cycle of PWM control. Unlike other scheme which filters the PWM signal for analog dimming, TPS61158 regulation voltage is independent of the PWM logic voltage level which often has large variations.

For optimum performance, use the PWM dimming frequency in the range of 20kHz to 100kHz. Since the CTRL pin is logic only pin, adding an external RC filter applied to the pin does not work.

The minimum dimming duty cycle the IC can support is 1% within the PWM dimming frequency range 20kHz~100kHz.

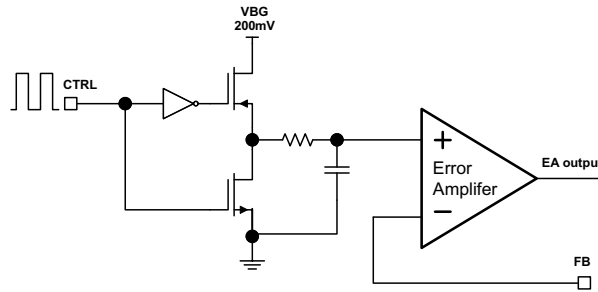

Figure 17. Block Diagram of Programmable FB Voltage Using PWM Signal

DIGITAL 1 WIRE BRIGHTNESS DIMMING

The CTRL pin features a simple digital interface to allow digital brightness control. The digital dimming can save the processor power and battery life as it does not require a PWM signal all the time, and the processor can enter idle mode if available.

The TPS61158 adopts the EasyScale™ protocol for the digital dimming, which can program the FB voltage to any of the 32 steps with single command. The step increment increases with the voltage to produce pseudo logarithmic curve for the brightness step. See the [Table 1](#) for the FB pin voltage steps. The default step is full scale when the device is first enabled ($V_{FB} = 200\text{mV}$). The programmed reference voltage is stored in an internal register. A power reset clears the register value and reset it to default.

EasyScale™: 1 WIRE DIGITAL DIMMING

EasyScale is a simple but flexible one pin interface to configure the FB voltage. The interface is based on a master-slave structure, where the master is typically a microcontroller or application processor. [Figure 18](#) and [Table 2](#) give an overview of the protocol. The protocol consists of a device specific address byte and a data byte. The device specific address byte is fixed to 58 hex. The data byte consists of five bits for information, two address bits ("00"), and the RFA bit. The RFA bit set to high indicates the Request for Acknowledge condition. The Acknowledge condition is only applied if the protocol was received correctly. The advantage of EasyScale compared with other one pin interfaces is that its bit detection is in a large extent independent from the bit transmission rate. It can automatically detect bit rates between 1.1kBit/sec and up to 100kBit/sec.

Table 1. Selectable FB Voltage

	FB VOLTAGE (mV)	D4	D3	D2	D1	D0
0	0	0	0	0	0	0
1	5	0	0	0	0	1
2	8	0	0	0	1	0
3	11	0	0	0	1	1
4	14	0	0	1	0	0
5	17	0	0	1	0	1
6	20	0	0	1	1	0
7	23	0	0	1	1	1
8	26	0	1	0	0	0
9	29	0	1	0	0	1
10	32	0	1	0	1	0
11	35	0	1	0	1	1
12	38	0	1	1	0	0
13	44	0	1	1	0	1
14	50	0	1	1	1	0
15	56	0	1	1	1	1
16	62	1	0	0	0	0
17	68	1	0	0	0	1
18	74	1	0	0	1	0
19	80	1	0	0	1	1
20	86	1	0	1	0	0
21	92	1	0	1	0	1
22	98	1	0	1	1	0
23	104	1	0	1	1	1
24	116	1	1	0	0	0
25	128	1	1	0	0	1
26	140	1	1	0	1	0
27	152	1	1	0	1	1
28	164	1	1	1	0	0
29	176	1	1	1	0	1
30	188	1	1	1	1	0
31	200	1	1	1	1	1

DATA IN

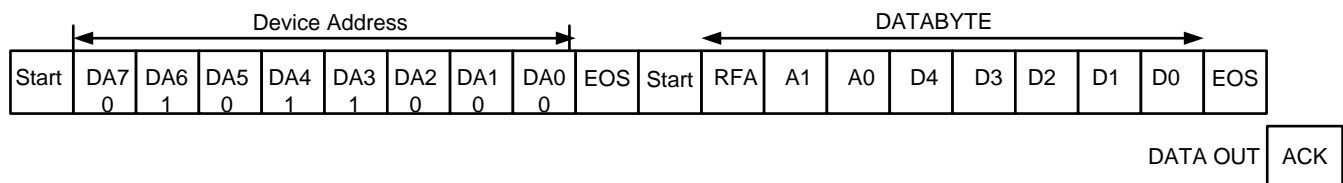

Figure 18. EasyScale™ Protocol Overview

Table 2. EasyScale™ Bit Description

BYTE	BIT NUMBER	NAME	TRANSMISSION DIRECTION	DESCRIPTION
Device Address Byte 72 hex	7	DA7	IN	0 (MSB device address)
	6	DA6		1
	5	DA5		0
	4	DA4		1
	3	DA3		1
	2	DA2		0
	1	DA1		0
	0	DA0		0 (LSB device address)
Data byte	7 (MSB)	RFA	IN	Request for acknowledge. If high, acknowledge is applied by device.
	6	A1		0 (Address bit A1)
	5	A0		0 (Address bit A0)
	4	D4		Data bit D4
	3	D3		Data bit D3
	2	D2		Data bit D2
	1	D1		Data bit D1
	0 (LSB)	D0		Data bit D0
		ACK	OUT	Acknowledge condition active 0, this condition will only be applied to case RFA bit is set. Open drain output, line needs to be pulled high by the host with a pullup resistor. This feature can only be used if the master has an open drain output stage. In case of a push pull output stage Acknowledge condition may not be requested!

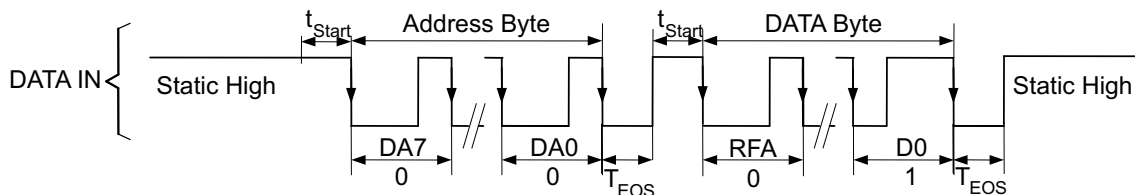

Figure 19. Easy Scale Timing, without acknowledge (RFA = 0)

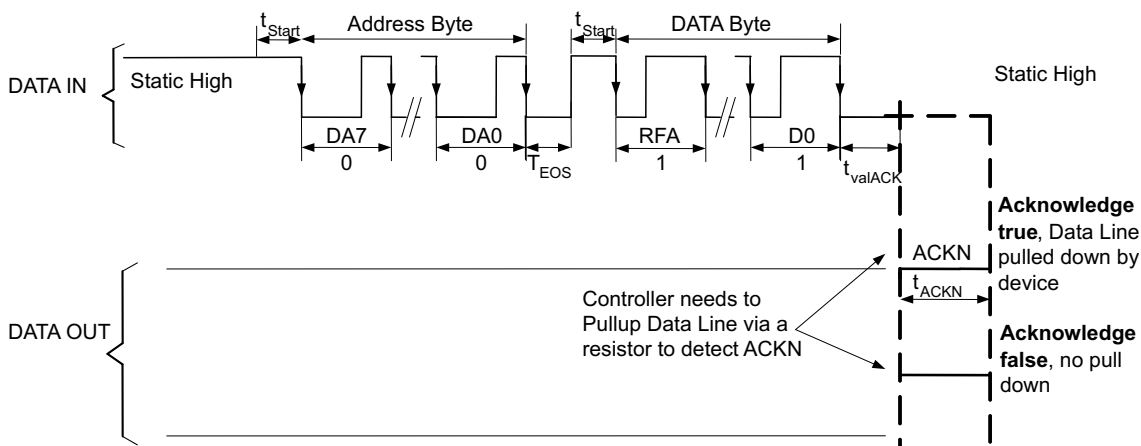

Figure 20. Easy Scale Timing, with acknowledge (RFA = 1)

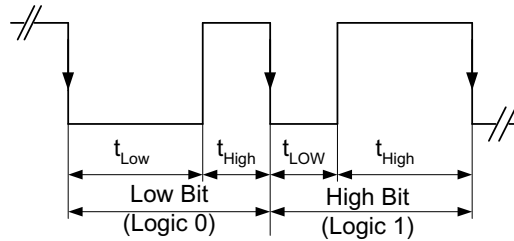

Figure 21. EasyScale™— Bit Coding

All bits are transmitted MSB first and LSB last. [Figure 19](#) shows the protocol without acknowledge request (Bit RFA = 0), [Figure 20](#) with acknowledge (Bit RFA = 1) request. Prior to both bytes, device address byte and data byte, a start condition must be applied. For this, the CTRL pin must be pulled high for at least t_{start} (3.5 μ s) before the bit transmission starts with the falling edge. If the CTRL pin is already at high level, no start condition is needed prior to the device address byte. The transmission of each byte is closed with an End of Stream condition for at least t_{EOS} (3.5 μ s).

The bit detection is based on a Logic Detection scheme, where the criterion is the relation between t_{LOW} and t_{HIGH} (refer to [Figure 21](#)). It can be simplified to:

- Low Bit (Logic 0): $t_{LOW} \geq 2 \times t_{HIGH}$
- High Bit (Logic 1): $t_{HIGH} \geq 2 \times t_{LOW}$

The bit detection starts with a falling edge on the CTRL pin and ends with the next falling edge. Depending on the relation between t_{HIGH} and t_{LOW} , the logic 0 or 1 is detected.

The acknowledge condition is only applied if:

- Acknowledge is requested by setting RFA bit to 1.
- The transmitted device address matches with the device address of the IC
- Device address byte and data byte are received correctly.

If above conditions are met, after t_{valACK} (3.5 μ s) delay from the moment when the last falling edge of the protocol is detected, an internal ACKN-MOSFET is turned on to pull the CTRL pin low for the time t_{ACKN} (900 μ s maximum), then the Acknowledge condition is valid. During the t_{valACK} delay, the master controller keeps the line low; after the delay, it should release the line by outputting high impedance and then detect the acknowledge condition. If it reads back a logic 0, it means the IC has received the command correctly. The CTRL pin can be used again by the master when the acknowledge condition ends after t_{ACKN} time.

Note that the acknowledge condition can only be requested in case the master device has an open drain output. For a push-pull output stage, the use a series resistor in the CTRL line to limit the current to 500 μ A is recommended to for such cases as:

- an accidentally requested acknowledge, or
- to protect the internal ACKN-MOSFET.

UNDERVOLTAGE LOCKOUT

An undervoltage lockout prevents operation of the device at input voltages below typical 2.2V. When the input voltage is below the undervoltage threshold, the device is shutdown and the internal switch FET is turned off. If the input voltage rises by undervoltage lockout hysteresis, the IC restarts.

OPEN LED PROTECTION

Open LED protection circuitry prevents IC damage as the result of white LED disconnection. The TPS61158 monitors the voltages at the VOUT pin and FB pin. The circuitry turns off the switch FET and shuts down the IC completely if both of the following two conditions are met: 1) the VOUT voltage reaches OVP threshold (28.2V typical), 2) FB voltage is lower than half of its regulation voltage. This means the LED string is open or the FB pin is short to ground. As a result, the output voltage falls to the level of the input supply. The device remains in shutdown mode until it is enabled by pulling down the CTRL pin logic low for at least 3.5ms and then pulling it high.

THERMAL SHUTDOWN

An internal thermal shutdown turns off the device when the typical junction temperature of 160°C is exceeded. The device is released from shutdown automatically when the junction temperature decreases by 15°C.

APPLICATION INFORMATION

MAXIMUM OUTPUT CURRENT

The overcurrent limit in a boost converter limits the maximum input current and thus maximum input power for a given input voltage. Maximum output power is less than maximum input power due to power conversion losses. Therefore, the current limit setting, input voltage, output voltage and efficiency can all change maximum current output. The current limit clamps the peak inductor current; therefore, the ripple has to be subtracted to derive maximum DC current. The ripple current is a function of switching frequency, inductor value and duty cycle. The following equations take into account of all the above factors for maximum output current calculation.

$$I_P = \frac{1}{L \times F_S \times \left(\frac{1}{V_{OUT} + V_F - V_{IN}} + \frac{1}{V_{IN}} \right)} \quad (3)$$

Where

I_P = inductor peak to peak ripple

L = inductor value

F_S = switching frequency

V_{OUT} = output voltage of the boost converter. It is equal to the sum of V_{FB} and the voltage drop across LEDs.

V_F = forward voltage of internal power diode. 0.75V typical

$$I_{OUT_max} = \frac{V_{IN} \times (I_{LIM} - I_P / 2) \times \eta}{V_{OUT}} \quad (4)$$

Where

I_{OUT_max} = maximum output current of the boost converter

I_{LIM} = over current limit

η = boost efficiency (85%, typical)

To calculate the maximum output current in the worst case, use the minimum input voltage, maximum output voltage and maximum forward voltage of internal power diode (1V). In order to leave enough design margin, the minimum current limit value 0.5A, the minimum switching frequency 600kHz, the inductor value with -30% tolerance, and a low power conversion efficiency, such as 80% or lower are recommended for the calculation. For instance, when minimum V_{IN} is 3.0V, 8 LEDs output equivalent to V_{OUT} is 26V, the inductor is 22 μ H, then the maximum output current is 33mA in the worst case.

INDUCTOR SELECTION

The selection of the inductor affects steady state operation as well as transient behavior, loop stability and the power conversion efficiency. These factors make it the most important component in power regulator design. There are three important inductor specifications, inductor value, DC resistance and saturation current. Considering inductor value alone is not enough. The inductor value determines the inductor ripple current. Choose an inductor that can handle the necessary peak current without saturating, according to half of the peak-to-peak ripple current given by [Equation 3](#), plus the inductor DC current given by:

$$I_{in_DC} = \frac{V_{OUT} \times I_{OUT}}{V_{IN} \times \eta} \quad (5)$$

Inductor values can have $\pm 20\%$ or even $\pm 30\%$ tolerance with no current bias. When the inductor current approaches saturation level, its inductance can decrease 20% to 35% from the 0A value depending on how the inductor vendor defines saturation. When selecting an inductor, please make sure its rated current, especially the saturation current, is larger than its peak current during the operation. Using an inductor with a smaller inductance value causes larger current ripple. This reduces the boost converter's maximum output current, causes large input voltage ripple and reduces efficiency. Large inductance value provides much more output current and higher conversion efficiency. For these reasons, a 10 μ H to 22 μ H inductor value range is recommended. A 22 μ H inductor optimizes the efficiency for most application while maintaining low inductor peak to peak ripple. [Table 3](#) lists the recommended inductors for TPS61158. TPS61158 has built-in slope compensation to avoid sub-harmonic oscillation associated with current mode control. If the inductor value is lower than 10 μ H, the slope compensation may not be adequate, and the loop can be unstable. Therefore, customers need to verify the inductor in their application if it is different from the recommended values.

Table 3. Recommended Inductors

PART NUMBER	L (μH)	DCR MAX (mΩ)	SATURATION CURRENT (A)	Size (L x W x H mm)	VENDOR
LPS3015-103ML	10	440	0.73	3.0 x 3.0 x 1.5	Coilcraft
LPS3015-223ML	22	825	0.5	3.0 x 3.0 x 1.5	Coilcraft
1229AS-H-100M	10	288	0.75	3.5 x 3.7 x 1.2	TOKO
1229AS-H-220M	22	672	0.5	3.5 x 3.7 x 1.2	TOKO
VLS3012ET-100M	10	336	0.64	3.0 x 3.0 x 1.2	TDK
VLS3012ET-220M	22	756	0.44	3.0 x 3.0 x 1.2	TDK

INPUT AND OUTPUT CAPACITOR SELECTION

The output capacitor is mainly selected to meet the requirements for the output ripple and loop stability. This ripple voltage is related to the capacitor's capacitance and its equivalent series resistance (ESR). Assuming a capacitor with zero ESR, the minimum capacitance needed for a given ripple can be calculated by

$$C_{OUT} = \frac{(V_{OUT} - V_{IN}) \times I_{OUT}}{V_{OUT} \times F_S \times V_{ripple}} \quad (6)$$

Where: V_{ripple} = peak-to-peak output ripple. The additional output ripple component caused by ESR is calculated using:

$$V_{ripple_ESR} = I_{OUT} \times R_{ESR} \quad (7)$$

Due to its low ESR, V_{ripple_ESR} can be neglected for ceramic capacitors, but must be considered if tantalum or electrolytic capacitors are used.

Care must be taken when evaluating a ceramic capacitor's derating under DC bias, aging and AC signal. The DC bias can significantly reduce capacitance. Ceramic capacitors can lose as much as 50% of its capacitance at its rated voltage. Therefore, leave the margin on the voltage rating to ensure adequate capacitance at the required output voltage.

The capacitor in the range of 1μF to 10μF is recommended for input side. The output requires a capacitor in the range of 0.47μF to 2.2μF. The output capacitor affects the loop stability of the boost regulator. If the output capacitor is below the range, the boost regulator can potentially become unstable.

The popular vendors for high value ceramic capacitors are:

TDK (<http://www.component.tdk.com/components.php>)

Murata (<http://www.murata.com/cap/index.html>)

LAYOUT CONSIDERATION

As for all switching power supplies, especially those high frequency and high current ones, layout is an important design step. If layout is not carefully done, the regulator could suffer from instability as well as noise problems. Therefore, use wide and short traces for high current paths. The input capacitor C_{in} needs to be close to the VIN pin and GND pin in order to reduce the input ripple seen by the IC. If possible, choose higher capacitance value for it. If the ripple seen at VIN pin is so large that it affects the boost loop stability or internal circuits operation, R1 and C1 is recommended to compose a filter to decouple the noise (refer to [Figure 23](#)). The SW pin carries high current with fast rising and falling edges. Therefore, the connection between the SW pin to the inductor should be kept as short and wide as possible. The output capacitor C_{out} should be put close to VOUT pin. It is also beneficial to have the ground of C_{out} close to the GND pin since there is large ground return current flowing between them. FB resistor should be put close to FB pin. When laying out signal grounds, it is recommended to use short traces separated from power ground traces, and connect them together at a single point close to the GND pin.

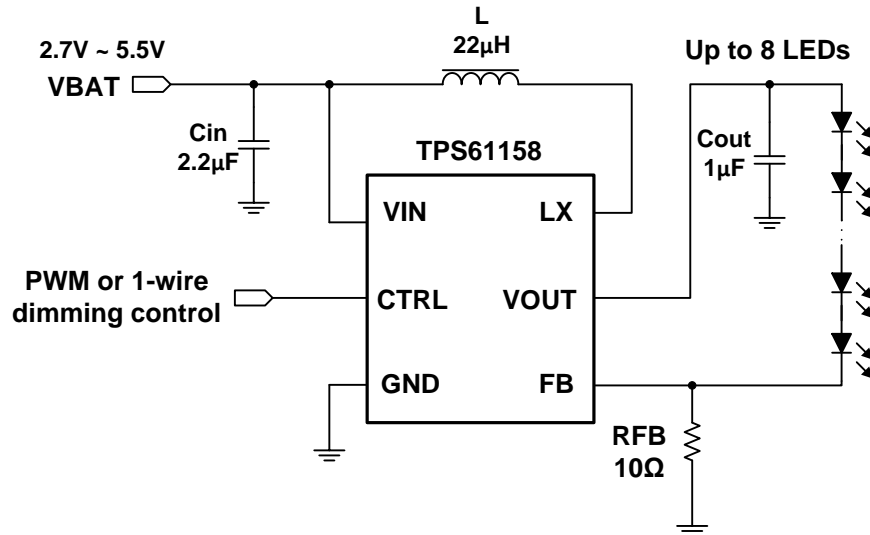
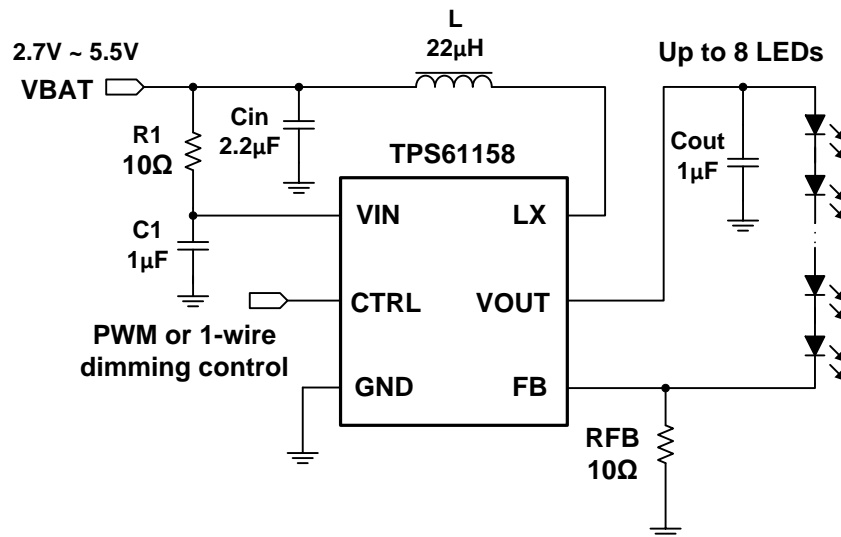
ADDITIONAL APPLICATION CIRCUITS

Figure 22. TPS61158 to Drive up to 8 LEDs

Figure 23. TPS61158 to Drive up to 8 LEDs with RC Filter at VIN Pin

PACKAGING INFORMATION

Orderable Device	Status (1)	Package Type	Package Drawing	Pins	Package Qty	Eco Plan (2)	Lead/Ball Finish	MSL Peak Temp (3)	Op Temp (°C)	Top-Side Markings (4)	Samples
TPS61158DRVR	PREVIEW	SON	DRV	6	3000	Green (RoHS & no Sb/Br)	CU NIPDAU	Level-2-260C-1 YEAR	-40 to 85	SIW	
TPS61158DRVT	PREVIEW	SON	DRV	6	250	Green (RoHS & no Sb/Br)	CU NIPDAU	Level-2-260C-1 YEAR	-40 to 85	SIW	

(1) The marketing status values are defined as follows:

ACTIVE: Product device recommended for new designs.

LIFEBUY: TI has announced that the device will be discontinued, and a lifetime-buy period is in effect.

NRND: Not recommended for new designs. Device is in production to support existing customers, but TI does not recommend using this part in a new design.

PREVIEW: Device has been announced but is not in production. Samples may or may not be available.

OBSOLETE: TI has discontinued the production of the device.

(2) Eco Plan - The planned eco-friendly classification: Pb-Free (RoHS), Pb-Free (RoHS Exempt), or Green (RoHS & no Sb/Br) - please check <http://www.ti.com/productcontent> for the latest availability information and additional product content details.

TBD: The Pb-Free/Green conversion plan has not been defined.

Pb-Free (RoHS): TI's terms "Lead-Free" or "Pb-Free" mean semiconductor products that are compatible with the current RoHS requirements for all 6 substances, including the requirement that lead not exceed 0.1% by weight in homogeneous materials. Where designed to be soldered at high temperatures, TI Pb-Free products are suitable for use in specified lead-free processes.

Pb-Free (RoHS Exempt): This component has a RoHS exemption for either 1) lead-based flip-chip solder bumps used between the die and package, or 2) lead-based die adhesive used between the die and leadframe. The component is otherwise considered Pb-Free (RoHS compatible) as defined above.

Green (RoHS & no Sb/Br): TI defines "Green" to mean Pb-Free (RoHS compatible), and free of Bromine (Br) and Antimony (Sb) based flame retardants (Br or Sb do not exceed 0.1% by weight in homogeneous material)

(3) MSL, Peak Temp. -- The Moisture Sensitivity Level rating according to the JEDEC industry standard classifications, and peak solder temperature.

(4) Multiple Top-Side Markings will be inside parentheses. Only one Top-Side Marking contained in parentheses and separated by a "~" will appear on a device. If a line is indented then it is a continuation of the previous line and the two combined represent the entire Top-Side Marking for that device.

Important Information and Disclaimer: The information provided on this page represents TI's knowledge and belief as of the date that it is provided. TI bases its knowledge and belief on information provided by third parties, and makes no representation or warranty as to the accuracy of such information. Efforts are underway to better integrate information from third parties. TI has taken and continues to take reasonable steps to provide representative and accurate information but may not have conducted destructive testing or chemical analysis on incoming materials and chemicals. TI and TI suppliers consider certain information to be proprietary, and thus CAS numbers and other limited information may not be available for release.

In no event shall TI's liability arising out of such information exceed the total purchase price of the TI part(s) at issue in this document sold by TI to Customer on an annual basis.

MECHANICAL DATA

DRV (S-PWSON-N6)

PLASTIC SMALL OUTLINE NO-LEAD

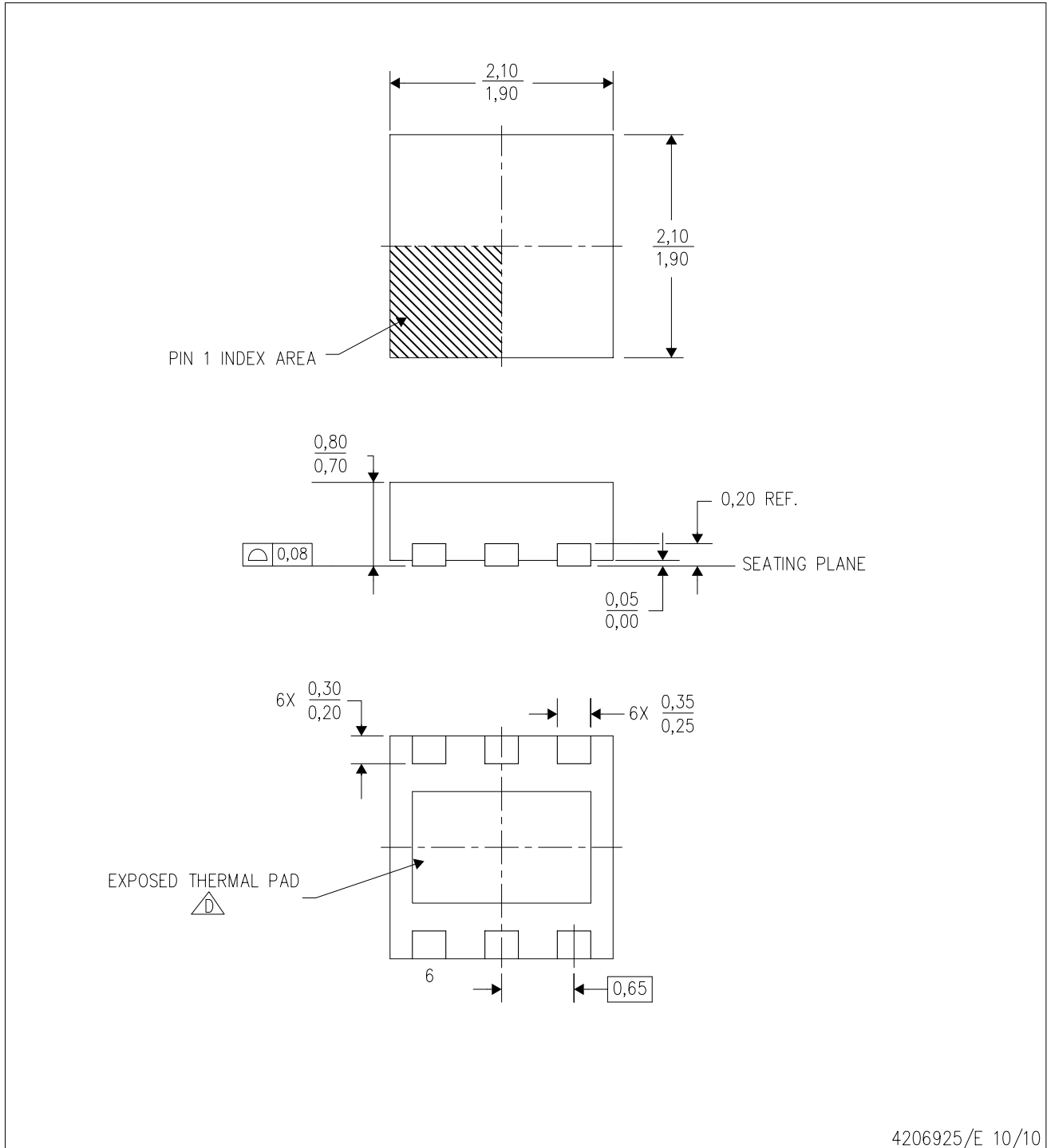

4206925/E 10/10

- NOTES:
- All linear dimensions are in millimeters. Dimensioning and tolerancing per ASME Y14.5M-1994.
 - This drawing is subject to change without notice.
 - Small Outline No-Lead (SON) package configuration.
- D** The package thermal pad must be soldered to the board for thermal and mechanical performance. See the Product Data Sheet for details regarding the exposed thermal pad dimensions.

THERMAL PAD MECHANICAL DATA

DRV (S-PWSON-N6)

PLASTIC SMALL OUTLINE NO-LEAD

THERMAL INFORMATION

This package incorporates an exposed thermal pad that is designed to be attached directly to an external heatsink. The thermal pad must be soldered directly to the printed circuit board (PCB). After soldering, the PCB can be used as a heatsink. In addition, through the use of thermal vias, the thermal pad can be attached directly to the appropriate copper plane shown in the electrical schematic for the device, or alternatively, can be attached to a special heatsink structure designed into the PCB. This design optimizes the heat transfer from the integrated circuit (IC).

For information on the Quad Flatpack No-Lead (QFN) package and its advantages, refer to Application Report, QFN/SON PCB Attachment, Texas Instruments Literature No. SLUA271. This document is available at www.ti.com.

The exposed thermal pad dimensions for this package are shown in the following illustration.

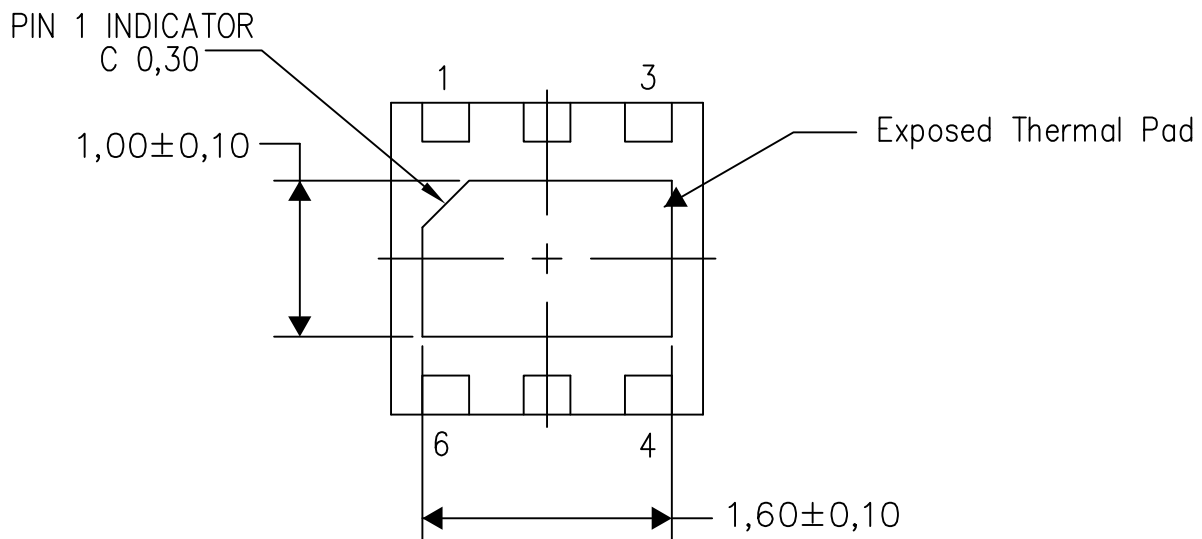

Bottom View

Exposed Thermal Pad Dimensions

4206926/N 03/13

NOTE: All linear dimensions are in millimeters

DRV (S-PWSON-N6)

PLASTIC SMALL OUTLINE NO-LEAD

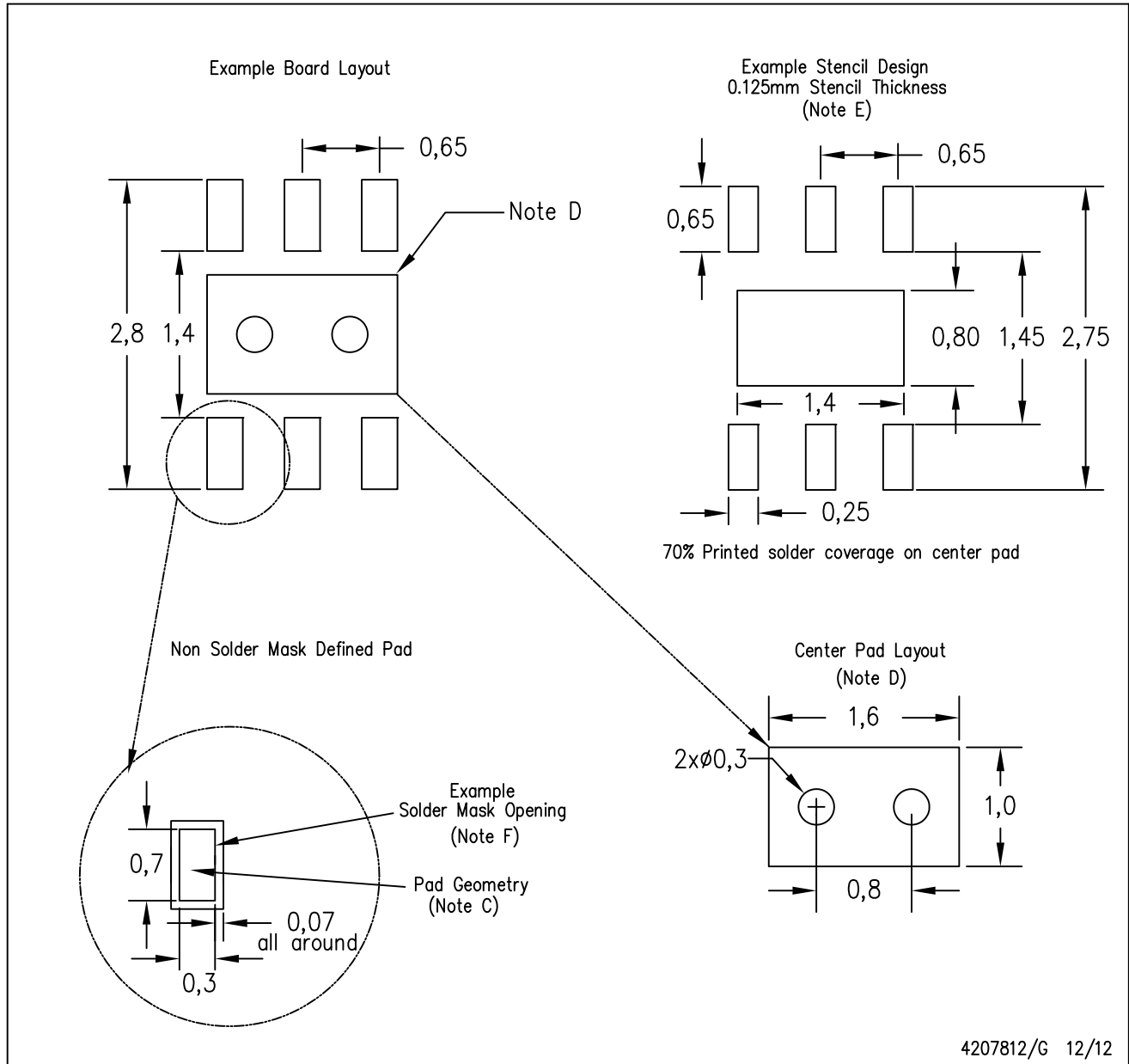

- NOTES:
- All linear dimensions are in millimeters.
 - This drawing is subject to change without notice.
 - Publication IPC-7351 is recommended for alternate designs.
 - This package is designed to be soldered to a thermal pad on the board. Refer to Application Note, QFN/SON PCB Attachment, Texas Instruments Literature No. SLUA271, and also the Product Data Sheets for specific thermal information, via requirements, and recommended board layout. These documents are available at www.ti.com <<http://www.ti.com>>.
 - Laser cutting apertures with trapezoidal walls and also rounding corners will offer better paste release. Customers should contact their board assembly site for stencil design recommendations. Refer to IPC 7525 for stencil design considerations.
 - Customers should contact their board fabrication site for solder mask tolerances.

IMPORTANT NOTICE

Texas Instruments Incorporated and its subsidiaries (TI) reserve the right to make corrections, enhancements, improvements and other changes to its semiconductor products and services per JESD46, latest issue, and to discontinue any product or service per JESD48, latest issue. Buyers should obtain the latest relevant information before placing orders and should verify that such information is current and complete. All semiconductor products (also referred to herein as "components") are sold subject to TI's terms and conditions of sale supplied at the time of order acknowledgment.

TI warrants performance of its components to the specifications applicable at the time of sale, in accordance with the warranty in TI's terms and conditions of sale of semiconductor products. Testing and other quality control techniques are used to the extent TI deems necessary to support this warranty. Except where mandated by applicable law, testing of all parameters of each component is not necessarily performed.

TI assumes no liability for applications assistance or the design of Buyers' products. Buyers are responsible for their products and applications using TI components. To minimize the risks associated with Buyers' products and applications, Buyers should provide adequate design and operating safeguards.

TI does not warrant or represent that any license, either express or implied, is granted under any patent right, copyright, mask work right, or other intellectual property right relating to any combination, machine, or process in which TI components or services are used. Information published by TI regarding third-party products or services does not constitute a license to use such products or services or a warranty or endorsement thereof. Use of such information may require a license from a third party under the patents or other intellectual property of the third party, or a license from TI under the patents or other intellectual property of TI.

Reproduction of significant portions of TI information in TI data books or data sheets is permissible only if reproduction is without alteration and is accompanied by all associated warranties, conditions, limitations, and notices. TI is not responsible or liable for such altered documentation. Information of third parties may be subject to additional restrictions.

Resale of TI components or services with statements different from or beyond the parameters stated by TI for that component or service voids all express and any implied warranties for the associated TI component or service and is an unfair and deceptive business practice. TI is not responsible or liable for any such statements.

Buyer acknowledges and agrees that it is solely responsible for compliance with all legal, regulatory and safety-related requirements concerning its products, and any use of TI components in its applications, notwithstanding any applications-related information or support that may be provided by TI. Buyer represents and agrees that it has all the necessary expertise to create and implement safeguards which anticipate dangerous consequences of failures, monitor failures and their consequences, lessen the likelihood of failures that might cause harm and take appropriate remedial actions. Buyer will fully indemnify TI and its representatives against any damages arising out of the use of any TI components in safety-critical applications.

In some cases, TI components may be promoted specifically to facilitate safety-related applications. With such components, TI's goal is to help enable customers to design and create their own end-product solutions that meet applicable functional safety standards and requirements. Nonetheless, such components are subject to these terms.

No TI components are authorized for use in FDA Class III (or similar life-critical medical equipment) unless authorized officers of the parties have executed a special agreement specifically governing such use.

Only those TI components which TI has specifically designated as military grade or "enhanced plastic" are designed and intended for use in military/aerospace applications or environments. Buyer acknowledges and agrees that any military or aerospace use of TI components which have **not** been so designated is solely at the Buyer's risk, and that Buyer is solely responsible for compliance with all legal and regulatory requirements in connection with such use.

TI has specifically designated certain components as meeting ISO/TS16949 requirements, mainly for automotive use. In any case of use of non-designated products, TI will not be responsible for any failure to meet ISO/TS16949.

Products

Audio	www.ti.com/audio
Amplifiers	amplifier.ti.com
Data Converters	dataconverter.ti.com
DLP® Products	www.dlp.com
DSP	dsp.ti.com
Clocks and Timers	www.ti.com/clocks
Interface	interface.ti.com
Logic	logic.ti.com
Power Mgmt	power.ti.com
Microcontrollers	microcontroller.ti.com
RFID	www.ti-rfid.com
OMAP Applications Processors	www.ti.com/omap
Wireless Connectivity	www.ti.com/wirelessconnectivity

Applications

Automotive and Transportation	www.ti.com/automotive
Communications and Telecom	www.ti.com/communications
Computers and Peripherals	www.ti.com/computers
Consumer Electronics	www.ti.com/consumer-apps
Energy and Lighting	www.ti.com/energy
Industrial	www.ti.com/industrial
Medical	www.ti.com/medical
Security	www.ti.com/security
Space, Avionics and Defense	www.ti.com/space-avionics-defense
Video and Imaging	www.ti.com/video

TI E2E Community

e2e.ti.com